

ODIN TEATRET:
Hamlet's Clouds

	projector
	spotlights
	LED lights
	chairs
	stairs
	aluminum structure with black and golden fabric

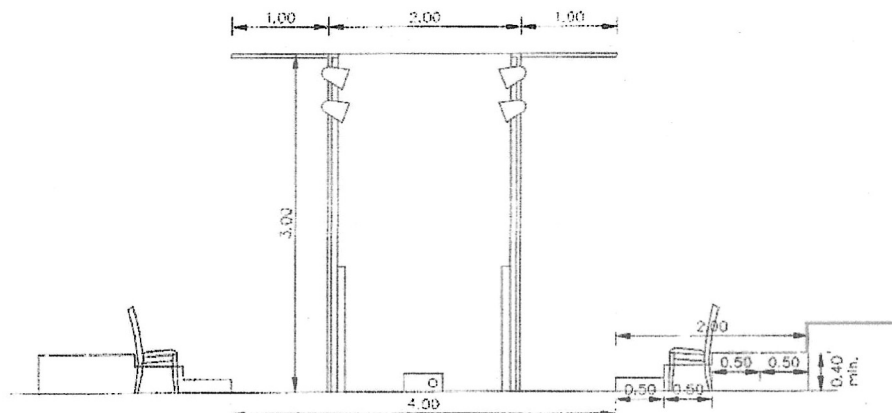

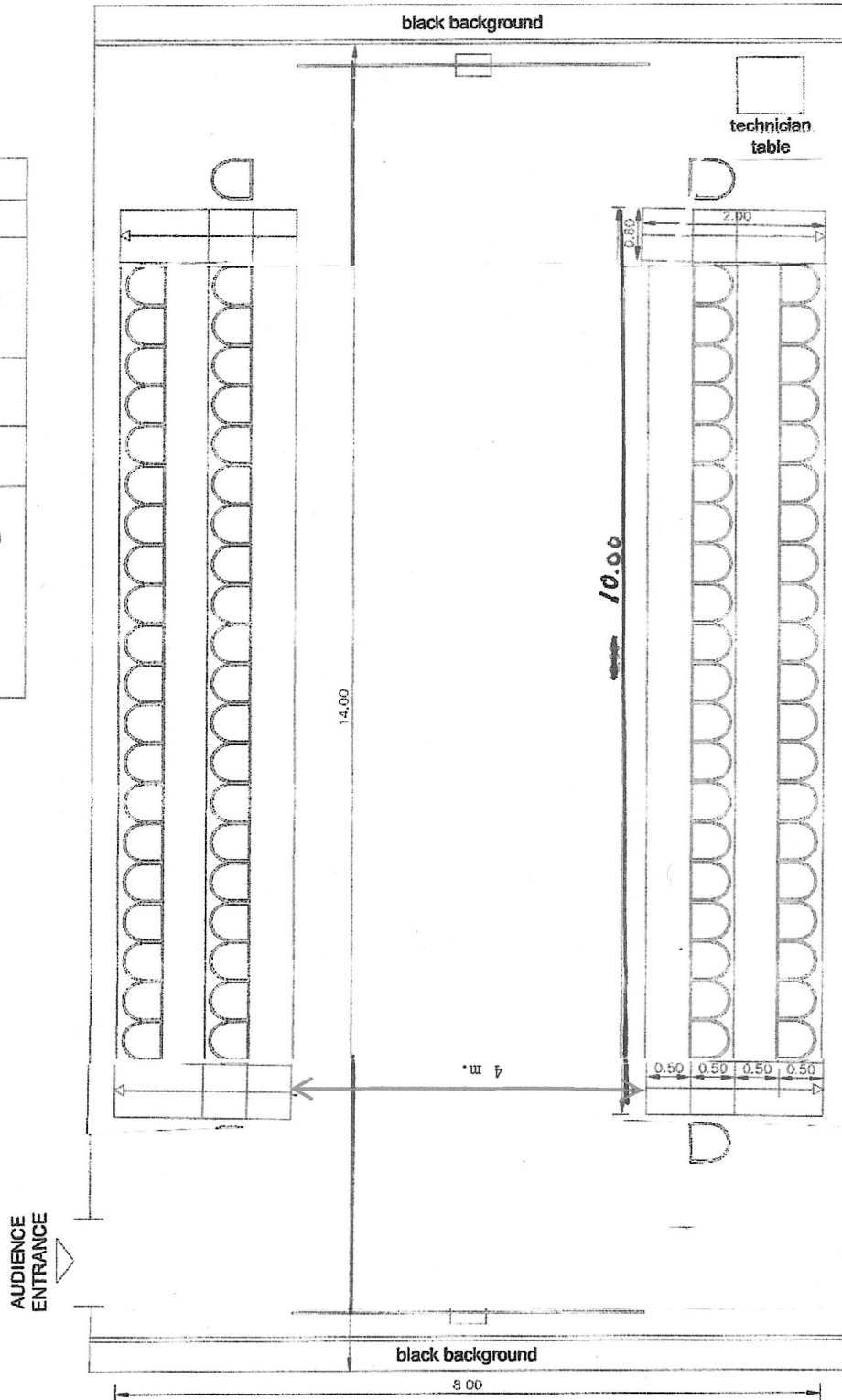

Odin Teatret

HAMLET'S CLOUDS

TECHNICAL INFORMATION AND REQUIREMENTS

LANGUAGE

The following languages are used during the performance: Danish, English, Spanish and Romanian. Some texts can be presented in Danish, English, French, Italian, Portuguese or Spanish to guide the spectator. No subtitles are used.

DURATION 70 min. (without a break)

PERFORMING SPACE

The acting area is 14 metres long, 4 metres wide and 3 metres high. The spectators occupy 50 cm of chair + 50 cm of leg room. Drawing included. Photos can be supplied.

If the entrance of the public is on the short side of the space: 15 metres long, 8 metres wide and 4 metres high. If the entrance of the public is on the long side of the space: 14 metres long, 9 metres wide and 4 metres high.

FLOOR

Black dance carpet is required on the acting area and should be provided by THE ORGANISER. Smooth and levelled with no inclination or holes. In the event of the floor not being completely level, or if unstable, THE ORGANISER must inform ODIN TEATRET as soon as possible.

THE SPACE / ROOM

The space/room must be clean and have a normal temperature for theatre work upon the arrival of ODIN TEATRET. Access to the room must be permitted for members of ODIN TEATRET during the whole period. The performance space must be completely blacked out, sound proofed against external noise, cleaned and empty at the arrival of ODIN TEATRET.

All inspections of the room must be completed 3 hours before the performance begins. From then on only members of ODIN TEATRET may enter the room.

No-one, including representatives of local authorities, technicians, fire inspectors, doormen, ushers etc. may be in the room during the performance, unless they are seated amongst the spectators, and therefore included in the number of seats. This is the responsibility of THE ORGANISER.

The performance space and dressing rooms must be secured. If it is not possible to secure the areas by locking doors a security guard must be arranged by THE ORGANISER.

ELECTRICITY, LIGHT AND SOUND

3x16 A, schuko sockets at the short sides and for the technician's table, 220 V

The electricity supply must be ready for connection upon the arrival of ODIN TEATRET.

ODIN TEATRET provides all lights, projectors and sound equipment necessary for the performance, the computer and telephone functioning as lighting board and video.

Lighting for the spectators' entrance should be provided by THE ORGANISER.



Odin Teatret

Cont. HAMLET'S CLOUDS TECHNICAL REQUIREMENTS, page 2/3

GET-IN AND GET-OUT

The space must be available to ODIN TEATRET a minimum of 12 hours before the first performance begins, and no less than 3 hours after the last performance, unless by special arrangement with THE ORGANISER.

VENTILATION / AIRING

It must be possible to switch off or regulate the ventilation/airing or the heating according to the needs of ODIN TEATRET. Noisy ventilation or heating must be switched off during the performance according to the needs of ODIN TEATRET.

DRESSING ROOMS

The dressing room must be close to the acting area.

The dressing room must be prepared with tables, chairs, mirrors and lights for 6 actors as well as clothes rails and hangers for their costumes.

One well-functioning steam iron and ironing board must be in the dressing room ready for use upon the arrival of ODIN TEATRET.

Toilet and running water must be in or near the dressing rooms, for the actors to use before and after the performance. The toilets must not be shared with the spectators.

The dressing room must be set up, cleaned and ready for use before the arrival of ODIN TEATRET.

THE ORGANISER will arrange for the performance space and dressing rooms to be cleaned after each performance according to needs of ODIN TEATRET.

Natural spring water must always be available.

SPECTATORS

THE ORGANISER will provide chairs and platforms of minimum height 40 cm for the second row of chairs, and 4 stairs to reach the platforms.

The performance has been conceived for $24 \times 4 = 96$ spectators. Of these 96 places will be managed by THE ORGANISER and the remaining 6 will be managed by ODIN TEATRET. One extra row of spectators on cushions on the floor can be added on each side of the acting area if needed.

Spectators on wheelchairs can be placed by taking away one chair.

All spectators enter into the performance space when the performance begins, in accordance with the instructions of ODIN TEATRET.

No-one, including representatives of local authorities, technicians, fire inspectors, doormen, ushers etc. may be in the room during the performance, unless they are seated amongst the spectators, and therefore included in the number of seats managed by THE ORGANISER.

A representative of THE ORGANISER must remain outside the room from one hour before the performance begins until the last spectator and actor has left the premises.

Late coming spectators, including employees and collaborators of THE ORGANISER, will not be admitted into the room once the performance has begun. It is the responsibility of THE ORGANISER to make this clear to staff, collaborators and to spectators through promotional material, outside the performance space and on tickets.





Odin Teatret

Cont. HAMLET'S CLOUDS TECHNICAL REQUIREMENTS, page 3/3

PHOTO, FILM AND SOUND RECORDING

It is NOT permitted to take photographs, make film documentation and/or sound recordings during the performance. This includes the press and employees of THE ORGANISER. It is the responsibility of THE ORGANISER to make this clear to the press, staff and spectators including using clear and visible signs at the entrance to the performing space.

Odin Teatret provides photos for the press.

CONTRACT

These technical requirements form part of the contract between Odin Teatret and THE ORGANISER. Any failure in fulfilling them can be considered breach of contract.

